

## Harmonic Analysis Of Three Phase Diode Clamped Multilevel Inverters

Vrinda Vijayan<sup>1</sup>, Sreehari S<sup>2</sup>

<sup>1</sup> PG Scholar, Electrical And Electronics Department, Adi Shankara Institute of Engineering And Technology, Kerala, India

<sup>2</sup> Assistant Professor, Electrical And Electronics Department, Adi Shankara Institute of Engineering And Technology, Kerala, India

**Abstract:** The conventional multilevel inverters (MLI) are generally categorized into three, they are diode clamped multilevel inverter, flying capacitor multilevel inverter and cascaded H bridge type multilevel inverter. These are having a more number of switches with less or more number of levels. Due to this problem, it can provides a more switching losses. And also it can require more drivers for turn ON the each switches. In this paper proposed a harmonic analysis of diode clamped multilevel inverter. Phase position modulation, Sinusoidal pulse width modulation (SPWM), Space Vector pulse width modulation (SVM), these are the common types of switching strategies. The multilevel converter is possesses much lower component voltage stress compared with the pulse width modulated (PWM) topologies. The SPWM control and pulse generator methods are selected as the comparison and the THD of the proposed system is analyzed by simulating in MATLAB/SIMULINK under different levels.

**Keywords:** MLI, SVM, SPWM, THD.

### I. Introduction

A multilevel converter is to attain higher power, and it use a series of power semiconductor switches with several lower voltage dc sources to perform the power conversion by generating a step voltage waveform [3]. Capacitors, batteries, and renewable energy voltage sources is used because multiple dc voltage sources. The commutation of the semiconductor power switches aggregate multiple dc sources. And so as to attain high voltage levels at the output; but, the rated voltage of the power semiconductor switches depends upon the rating of dc voltage sources to that they are connected [9].

The multilevel inverters are mainly divided into three they are: diode clamped inverter, flying capacitor inverter, H bridge inverter. Diode Clamped multilevel inverter - This inverter uses diodes and provides the various voltage levels through the various phases to the capacitor banks which are in series. The diode transfers a limited amount of voltage thereby reducing the strain on the other electronics devices. Obtaining maximum output voltage at half of the dc voltage. It is used in high power wind energy conversion systems [5]. Flying capacitor multilevel inverter - Involves series connection of capacitor clamped switching cells. One feature is that added clamping diodes are not needed. Furthermore, the flying capacitor inverter has switch redundancy at intervals the phase which might be used to balance the flying capacitors so one dc source is needed. The most advantage is each and every branch will be analysed severally and separately [6]. It's used for converters with Harmonic distortion capability, static VAR-compensation etc... Cascaded H-bridge multilevel inverter -The voltage total harmonic distortion could minimum. Usually, these are chosen so that predominant lower frequency harmonics, 5th, 7th, 11th, and 13th, harmonics are eliminated. Employed in high voltage variable frequency drives- high-voltage motor drives. The output wave kind will be either a sine or will be a modified sine wave [7].

In this paper proposed harmonic analysis of three phase diode clamped multilevel inverter. The multilevel converter is possesses much lower component voltage stress compared with the pulse width modulated (PWM) topologies. The SPWM control and pulse generator methods are selected as the comparison and the THD of the inverters is analysed by simulating in MATLAB/SIMULINK under different levels.

#### 1.1 Diode Clamped MLI

The concept of diode clamped MLI is to use diodes and provides the multiple voltage levels at the different phases. A diode transfers a limited amount of voltage, and thereby reducing the strain on other electrical devices. The maximum output voltage is getting half of the input DC voltage. It is the main drawback of the diode clamped multilevel inverter. This problem can be solved by increasing the switches, diodes [12]-[15]. These inverters provides high efficiency because the fundamental frequency used for all the switching devices. It is a simple method of the back to back power transfer systems [5].

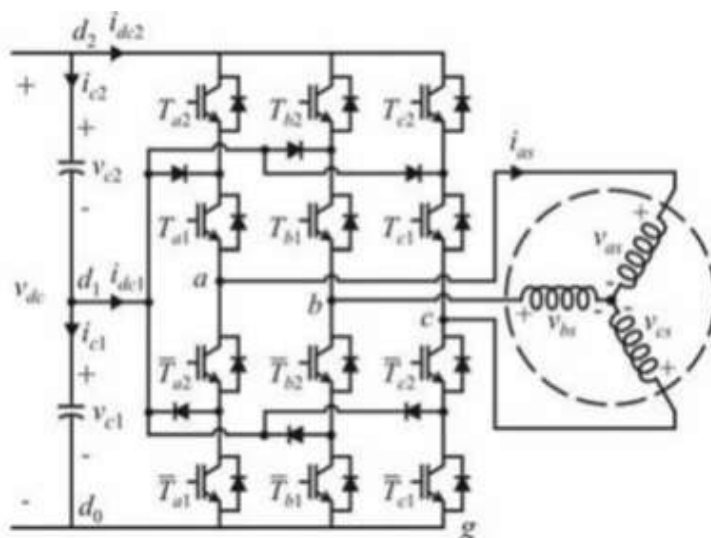

Fig.1. Three phase three level diode-clamped MLI.

According to the original invention, the concept will be extended to any number of levels by increasing the number of diodes. In this paper three phase three level inverter, and three phase six level inverters are using pulse generator and sinusoidal PWM are compared. And harmonic analysis is done using FFT analysis.

## II. Simulations And Results

The various multilevel inverters using with modulation and without modulation are simulated. Three phase three level, six level inverters using with modulation and without modulation are done and results are given below.

### 1.1 Three Phase Three Level Diode Clamped Inverter Using Pulse Generator

The Simulink model of three phase three level diode clamped inverter using pulse generator is shown in figure 2. Table.I shows the switching states of three phase three level MLI.

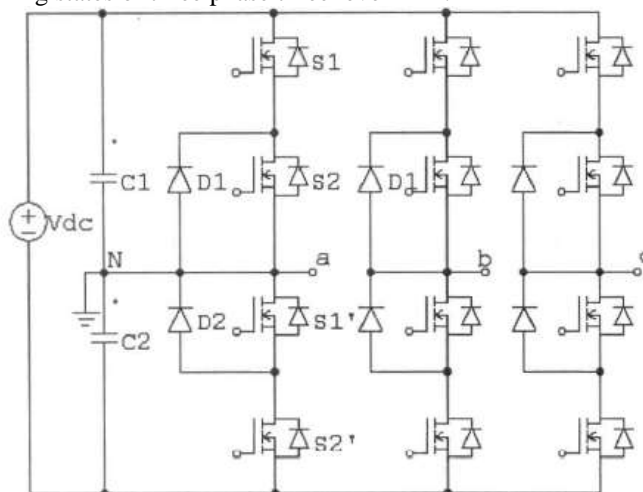

Fig.2. Power circuit of three phase 3-Level diode-clamped MLI.

Output Voltage	S <sub>1</sub>	S <sub>2</sub>	S <sub>1</sub> '	S <sub>2</sub> '
V <sub>dc</sub>	1	1	0	0
V <sub>dc</sub> /4	0	1	0	1
V <sub>dc</sub> /3	1	0	0	1
V <sub>dc</sub> /2	0	1	1	0
0	0	0	1	1

Table.I Switching states of three phase three level inverter

The output voltage (phase voltage) wave form and THD value is shown in figure 3 and figure 4. The input voltage is 400 V. Getting THD value is 44.06%.

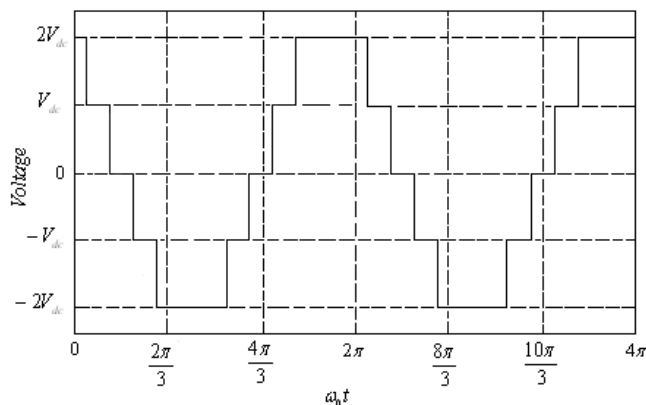

Fig.3. Line voltage waveform of 3-level MLI

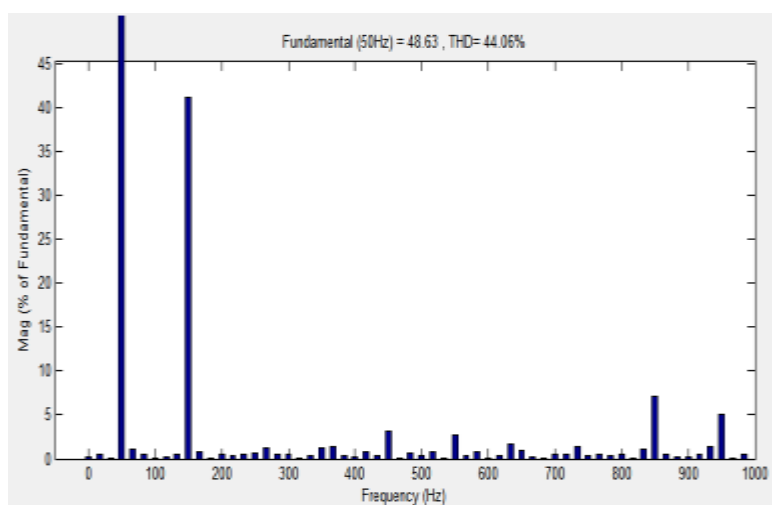

Fig.4. THD value of 3-Level diode-clamped MLI using Pulse generator

1.2 Three Phase Three Level Diode Clamped Inverter Using Spwm

The Simulink model of three phase three level diode clamped inverter using SPWM is shown in figure 5.

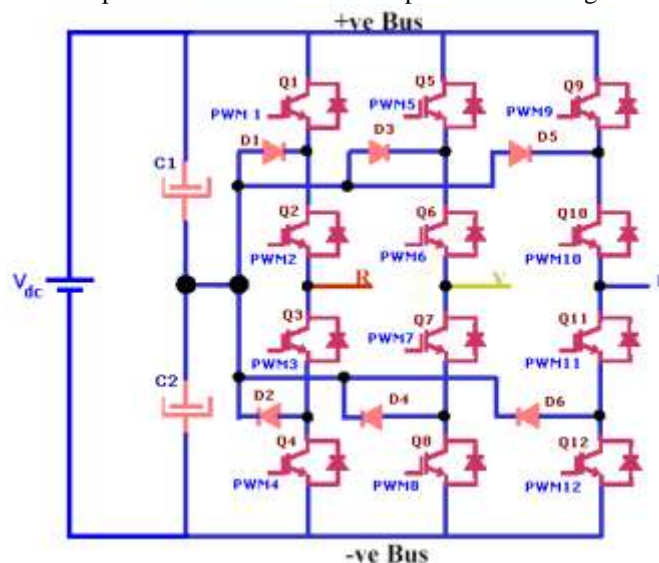

Fig.5. Simulink model of three phase three level inverter

The output voltage (phase voltage) wave form and THD value is shown in figure 6 and figure 7. The input voltage is 400 V. Getting output voltage is 400 V and THD value is 23.83%.

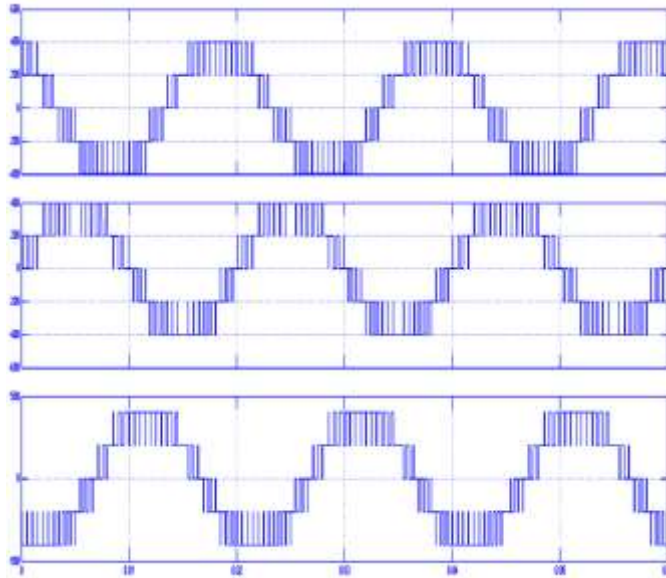

Fig.6. Voltage waveform of 3 Level inverter using SPWM

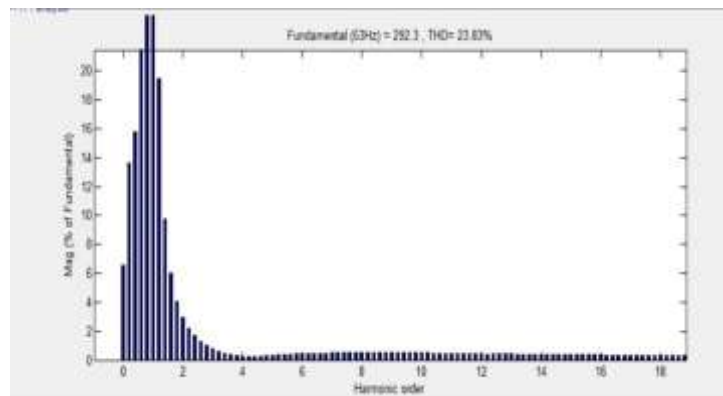

Fig.7. THD value of 3 Level diode-clamped MLI using SPWM

### 1.3 Three Phase Six Level Diode Clamped Inverter Using Pulse Generator.

The Simulink model of three phase three level diode clamped inverter using SPWM is shown in figure 8. Table.II Shows the switching states of three phase six level MLI.

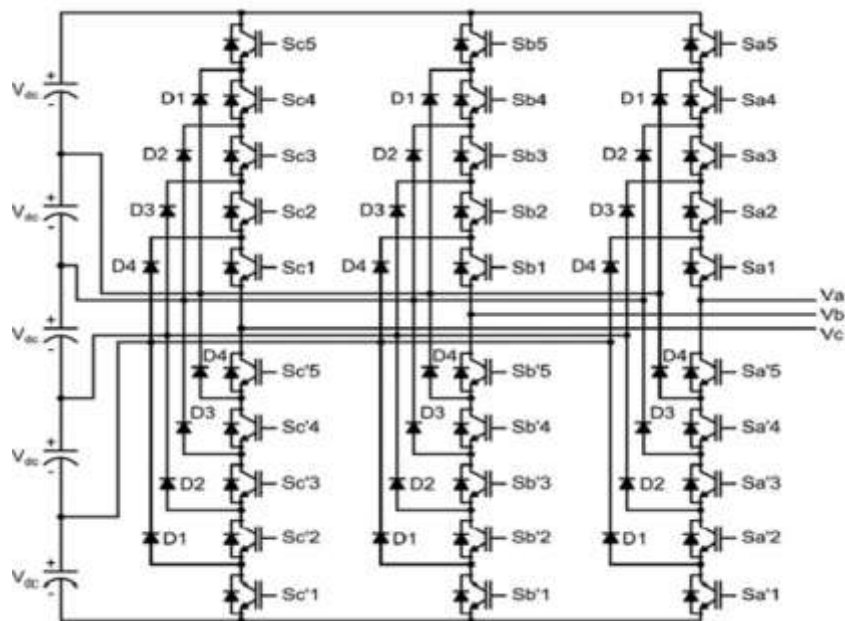

Fig.8. Circuit diagram of three phase six level inverter

Voltage $V_{a0}$	Switch State									
	$S_{a1}$	$S_{a2}$	$S_{a3}$	$S_{a4}$	$S_{a5}$	$S_{a'1}$	$S_{a'2}$	$S_{a'3}$	$S_{a'4}$	$S_{a'5}$
$V_5 = 5V_{dc}$	1	1	1	1	1	0	0	0	0	0
$V_4 = 4V_{dc}$	0	1	1	1	1	1	0	0	0	0
$V_3 = 3V_{dc}$	0	0	1	1	1	1	1	0	0	0
$V_2 = 2V_{dc}$	0	0	0	1	1	1	1	1	0	0
$V_1 = V_{dc}$	0	0	0	0	1	1	1	1	1	0
$V_0 = 0$	0	0	0	0	0	1	1	1	1	1

Table.II Switching states for three phase six level MLI.

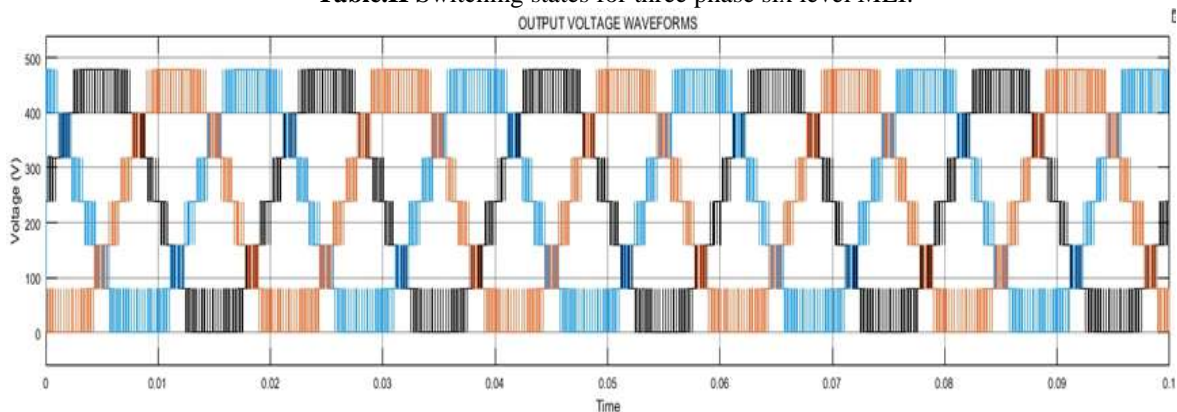

Fig.9. Voltage waveform of 6 Level inverter

The output voltage (phase voltage) wave form and THD value is shown in figure 9 and figure 10. The input voltage is 415 V. Getting output voltage is 400 V and THD value is 36.50%.

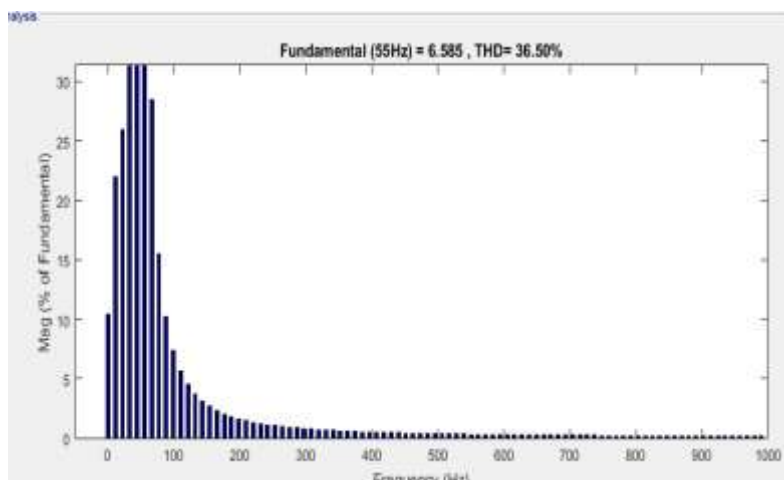

Fig.10. THD of 6-Level inverter using pulse generator

### 1.4 Three Phase Six Level Diode Clamped Inverter Using SPWM

The Simulink model of three phase three level diode clamped inverter using SPWM is shown in figure 8. The output voltage (phase voltage) wave form and THD value is shown in figure 11 and figure 12. The input voltage is 415 V. Getting output voltage is 415 V and THD value is 10.30%.

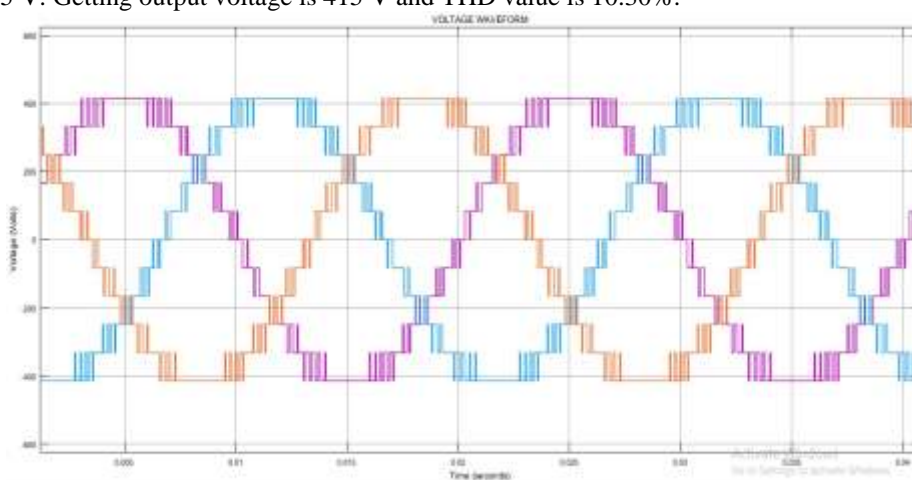

Fig.11: Voltage waveform of 6-Level inverter

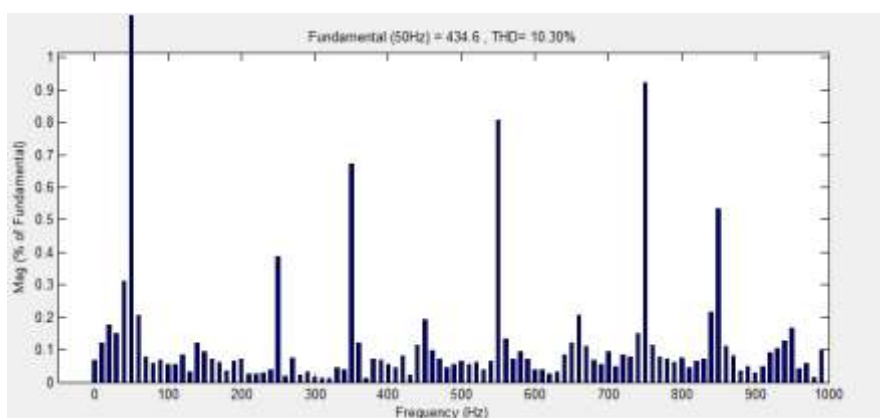

Fig.12: THD value of three phase 6-Level inverter

The table II shows the comparison of THDs in vottage and Table.III shows the comparison of THD in current. For comparing pulse generator and SPWM, the SPWM is much better than using pulse generator

Name	Using pulse generator	Using SPWM
Three phase three level inverter	44.06%	23.83%
Three phase six level inverter	33.25%	10.30%

**Table II.** Comparison of THD in voltage

Name	Using pulse generator	Using SPWM
Three phase three level inverter	8.34%	1.2%
Three phase six level inverter	5.51%	0.5%

**Table III.** Comparison of THD in current

### III. Conclusion

In this report, the survey of various multilevel inverter topologies and control strategies has been presented. The comparison of various inverters using pulse generator and SPWM is presented. And harmonic analysis is done using FFT analysis. When the number of levels increases the THD in voltage and THD in current is reduced. And the comparison of the control strategies the SPWM is much better than pulse generator scheme. The future work on the thesis includes a new three phase six level inverter with reduced number of components.

### Acknowledgements

This research was supported by Department of EEE, Adi Shankara Institute of Engineering and Technology, Kalady. We thank our colleagues who provided insight and expertise that greatly assisted the research, although they may not agree with all of the interpretations/conclusions of this paper.

### References

- [1] Mohamed Z. Youssef, Konrad Woronowicz and Kunwar Aditya, "Design and development of an efficient multilevel DC/AC traction inverter for railway transportation electrification". IEEE Trans. on Power Electron, Vol. 31, no. 4, April 2016.
- [2] S. Das and G. Narayanan, "Novel switching sequences for multilevel inverters", IEEE Trans. Ind. Electron., vol. 59, no. 3, pp. 1477-1487, Feb. 2012.
- [3] A. Knight, J. Salmon, and J. Ewanchuk, "Single phase multilevel PWM Inverters using Coupled Inductors", IEEE Trans. Power Electron, Vol. 24, no. 5, pp. 1259-1266, Mar. 2009.
- [4] G. Narayanan, D. Zhaao, K. Krishnamurthy, and A. Ayyannar "Space Vector based PWM techniques for reduced current ripple in multilevel inverters", IEEE Trans. Ind. Electron, vol. 55, no. 4, pp. 1614-1627, Apr. 2008.
- [5] Abhijit Choudhury, Pragasen Pillay, Sheldon S. Williamson, "A hybrid- pwm based dc-link voltage balancing Algorithm for a 3-level neutral-point-clamped (npc) dc/ac traction inverter drive", IEEE Transactions on Power Electronics, Cairo University, vol. 31, no. 4, april 2016.
- [6] Maheshkumar.N, Maheskumar .V, M.Divya, "The New Topology In Flying Capacitor Multilevel Inverter", 2013 International Conference on Computer Communication and Informatics (ICCCI -2013).
- [7] S. Le, Z. Wu, Ma Weiming, X Fei, et al, "Analysis of the DC-link capacitor current of power cells in cascaded H-bridge inverters for high-voltage drives" IEEE Trans. Power Electron, vol. 29 , no. 12, pp. 6281-6292, Dec. 2014.
- [8] A. M. Y. M. Ghias, J. Pou, M. Ciobotaru, V.G. Agelidis, "Voltage balancing method using phase-shifted PWM for the flying capacitor multilevel converter", IEEE Trans. Power Electron, vol. 29 , no. 9, pp. 4521-4531, Sep. 2014. 33
- [9] V. Yaramasu, B.Wu, and J. Chen, "Model-predictive control of grid-tied four level diode-clamped inverters for high-power wind energy conversion systems", IEEE Trans. Power Electron., vol. 29 , no. 6, pp. 2861-2873, Jun. 2014.
- [10] A. M. Y. M. Ghias, J. Pou, M. Ciobotaru, V.G. Agelidis, "Voltage balancing method using phase-shifted PWM for the flying capacitor multilevel converter", IEEE Trans. Power Electron, vol. 29 , no. 9, pp. 4521-4531, Sep. 2014
- [11] A. Ajami, J. O. M.Reza, M. K. Toopchi, A. Mokhberdorran, "Cascade multi-cell multilevel converter with reduced number of switches", IET Power Electron, vol. 7, no. 3, pp. 552-558, Mar. 2014.
- [12] Naja\_ E, Yatim AHM (2014), "Design and implementation of a new multilevel inverter topology", IEEE Trans Ind Electron. ,2012 Nov; 59(11):4148-54.
- [13] Ramesh Babu S, "Comparative Analysis of Cascaded Multilevel Inverter for Phase Disposition and Phase Shift Carrier PWM for Different Load", Indian Journal of Science and Technology, 2015 Apr; 8(57):25162.
- [14] Radan A, Shahirinia AH (2014), "Evaluation of carrier based PWM methods for multilevel inverters", Proc IEEE ISIE,2007. p. 38994.
- [15] G. Vijaykrishna and O. Chandra Shekhar (2015), "A Three Phase 7-Level and 9-Level Reversing Voltage Multilevel Inverter", Indian Journal of Science and Technology, Vol 8(23), DOI: 10.17485/ijst/2015/v8i23/70612, September 2015